

DS-200

Folder Inserter

The New Standard in Mail Production



Join us on



NEOPOST

Send.Receive.Connect.

The New Standard in Mail Production

The highly productive mail operating system that inserts an unprecedented variety of mail

There's no doubt about it: the ability to guarantee your mail production is essential for your business.

The inserter is one of the most important elements in your mail flow. It needs to be easy to operate, highly productive and flexible. Neopost's DS-200 has set new standards in all these aspects.



Step-By-Step Guide to Meet All Your Needs With Ease

The DS-200's 15" graphical touch screen maximizes ease of use. Simply select your job and you'll be up and running in no time.



Even changing from one job to a completely different one takes only a few minutes. The system adapts itself to all the settings programmed in the memory for the job you select.

But there is more to ease of use. And the DS-200 provides it every step of the way throughout your mail processing. From efficient paper and feeder loading to on screen error location.

The DS-200 guarantees optimum accessibility and sophisticated ergonomics. It provides quick, safe and easy access to the paper path



throughout the entire system, so you'll soon be back in business if there's a break in production. Handling and

processing your mail has never been so easy.

- Intuitive document loading eliminates guesswork.
- Day-to-day mail can be processed via the standard, dedicated manual-feed tray.

1. Cascade feeding for continuous run



2. Loading on the fly prevents stoppage



3. Flexible in a wide variety of inserts

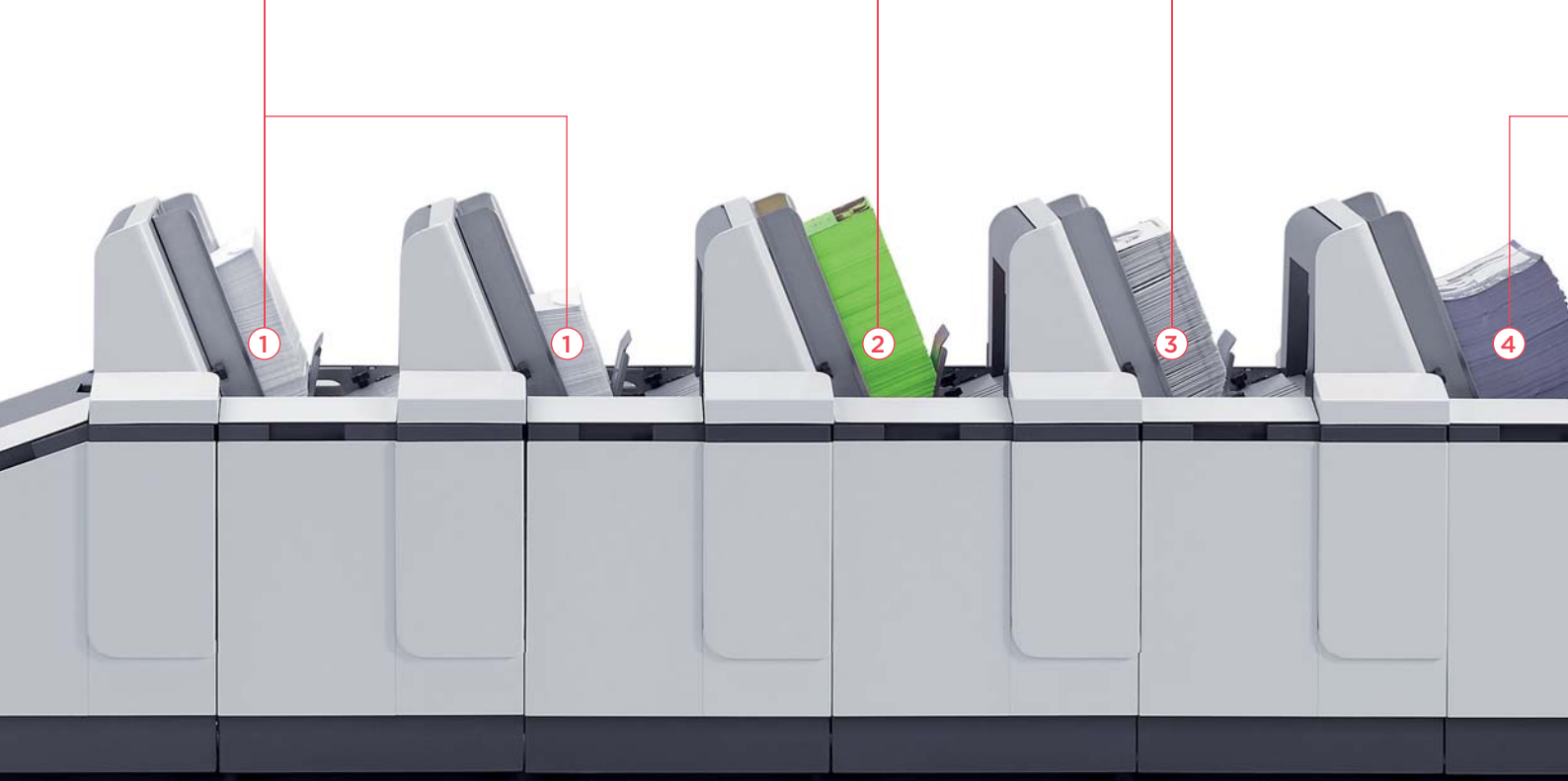

Highly Productive for The Widest Variety Of Mail



In addition to its amazing ease of use as a production inserter, the DS-200 also provides high speed performance. It can process up to 4,800 envelopes per hour. Because the DS-200 can process Landscape C4 envelopes, inserting up to 50 pages per envelope is now easier and more reliable.

Plus, the high loading capacity of the DS-200 is a perfect match for

its high speed. The system design reduces downtime, enabling you to work on other tasks at the same time - maximising your productivity.

Every part on the DS-200 is designed to perform for you. From the high-capacity feeders and feeder swap to the automatic



sheet diverter and the high capacity envelope output conveyor, the DS-200 delivers the high speed and perfect practicality you need.



- High-capacity feeders, fast accumulation, and on-the-fly envelope loading - all designed to save you time.
- Online services provide even better system uptime.

4. inserting up to 6mm thick booklets



5. Feeder Swap

Continuous operation is achieved by cascade feeding. If one feeder runs empty, another one takes over, giving a total capacity of 2,000 sheets.

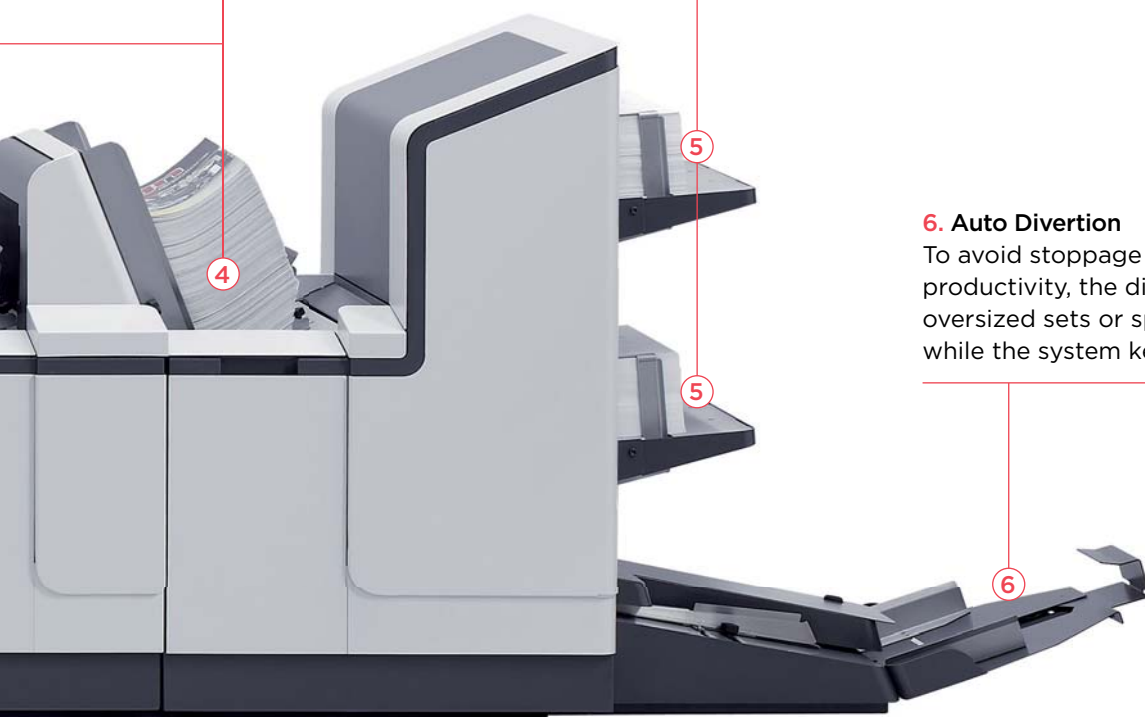

6. Auto Divertion

To avoid stoppage and maximize productivity, the divert bin receives oversized sets or special documents, while the system keeps running.



Insert Up To 50 Pages or 6mm Booklets

With its high-capacity sheet feeders combined with premium processing speed for multiple documents, the DS-200 is the perfect solution for the widest scope of mail applications. It can process coated and glossy booklets or CDs into all regular

envelopes ranging from C5/6 to C4. Plus it can feed documents both portrait or landscape.

Add this to the fact that the DS-200 is able to memorize an unlimited number of jobs to reduce set-up time and you can begin to imagine the unprecedented possibilities of the DS-200.

The DS-200 has been designed to run different jobs every day at the touch of a screen. Thanks to its intuitive handling, processing a large range of important mail batches or multiple and divergent documents, has never been as easy.

- On-the-fly document loading from simple letters to 6mm thick glossy booklets.
- Mechanical adjustments are automatically carried out after a new job from the unlimited envelope and document library has been selected.



7. Daily Mail Insertion



Automate Your Document Processing

Neopost's Output Management Software will get the best out of each and every of your documents.

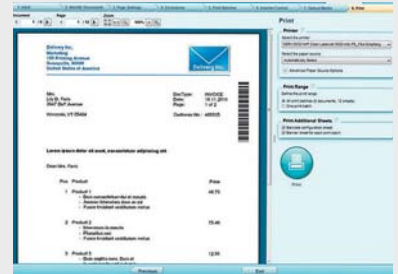

- Automatically add a Barcode or Datamatrix at the right place to drive your folder inserter.
- Remove your old OMR marks, giving more value to your documents.
- Select inserts from multiple trays.
- Guarantee your mail integrity with secure control marks.
- Split your print file based on number of pages.

Full Content Control and Security You Can Rely On

Thanks to its exclusive scanning device, the DS-200 can read any type of coding such as OMR 1 and 2 tracks, 1D barcodes and 2D datamatrix codes. Furthermore, the code can be printed anywhere on the document. This unique feature provides full flexibility to fulfill any layout requirement.

It provides the perfect basis for a complete, detailed and accurate report of your mail production – the DS-200 can deliver a full production report, including a record of each scanned document.

To securely process personalized mail runs and those with a varying volume of documents per set, the DS-200 includes several automatic features to ensure that every recipient receives precisely the right mail piece.

- Reading of sequencing marks allows you to control printing accuracy and select inserts based on customer profiles.
- Optional Integrity Checking Software ensures 100% accurate mail processing.

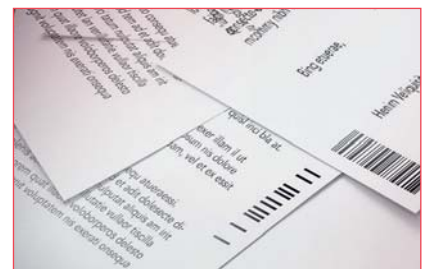

Features & Benefits



Adapt Your Modular System To Your Needs

The modular design, from 1 to 11 feeders, of the DS-200 gives you peace of mind when purchasing a system to ensure your future needs and job requests are fulfilled.

Automate Your Total Mail Flow

A full range of output solutions allows you to easily adapt your mail processing to any postal rule and to optimize your mail process expenses. This includes:

- Flexible sorting unit to manage up to 3 outputs
- Intelligent franking machine connection
- High capacity trays or conveyors

Why Choose Neopost?

Neopost is a global leader in mailing solutions, shipping services and digital communications. We believe that people are the key to business success. That's why our products and services are tailored to help your organization improve the quality of its interactions and bring people closer together.

In this age of multichannel communications, we guide and empower you to interact in new and innovative ways. We advise you on how to create cost-cutting synergies. And we deliver global coverage with a strong local presence, offering you continual support by phone, onsite or online.

Today, Neopost is present in 31 countries and has a network of partners in more than 90 countries. We promote responsible business and sustainable development through our products and outreach programs. And our 6,200 employees worldwide are committed to making your interactions more responsive and more powerful - offering you a competitive edge that will open up a wealth of business opportunities.

Find out more at neopost.ie

Operational Efficiency

Touch screen PC control	Yes
Speed Up to	4,800/hour
Automatic job set-up	Yes
Multiple sheet feeding	Yes
Cascade from feeders	Yes
Divert bin for documents	Yes
Job memory	No limitation
Hand feeding	Yes
Documents feeder capacity Up to	1,000
Envelope feeder capacity Up to	800
Fold types	letter, zigzag, single, double parallel, no fold $\triangle Z \angle \leftarrow _$
Folding capacity	Up to 8 sheets (80gsm)
Envelope conveyor	Yes (optional)
Document weight	70gsm to 6mm thick
Set thickness	6mm

Mail Quality & Security

Accumulation before folding	Yes (optional)
Optical Mark Recognition (OMR)	Yes (optional)
Barcode Recognition (BCR)	Yes (optional)
2D Datamatrix	Yes (optional)
Automatic double detection	Yes (all feeders)
Automatic document measurement	Yes (all feeders)

Budget Optimization

Full modularity from 1 to 11 feeders	Yes
--------------------------------------	-----

System Specification

Base (based on a 3 module configuration, ask for detailed footprint drawing based on your configuration)	
Length x Depth	2,720 mm x 635 mm
Weight	337kg